

MODEL

EP



INSTALLATION, OPERATION & MAINTENANCE MANUAL

EP Knife Gate Valve



SPAIN · UK · GERMANY · FRANCE · CANADA · USA · BRAZIL · CHILE · PERU · INDIA · CHINA

www.orbinox.com

INSTALLATION, OPERATION & MAINTENANCE MANUAL

EP Knife Gate Valve

- 0. INTRODUCTION
- 1. HANDLING
- 2. INSTALLATION
- 3. ACTUATORS
 - 3.1. Handwheel
 - 3.2. Lever
 - 3.3. Pneumatic
 - 3.4. Electric
- 4. MAINTENANCE
 - 4.1. Gland packing replacement
 - 4.2. Lubrication
- 5. STORAGE
- 6. ENVIRONMENTAL CONSIDERATIONS
- 7. PARTS LIST & DRAWING

0. INTRODUCTION

The EP model knife gate valve is a polyurethane-lined lug type valve designed for general industrial service applications with abrasive fluids.

The EP valve complies with the following European directives:

- Machinery Directive

When applicable it can also comply with the following additional directives:

- Pressure Equipment Directive
- Potentially Explosive Atmospheres (ATEX)

It is the user's liability to verify the maximum working conditions (PS, TS), medium (gas or liquid) and dangerousness group (1 or 2) and if the fluid is unstable to properly classify the valve according to the PED directive.

ORBINOX offers, supplies and certifies valves according to the information received from the customer. The customer is liable to make sure this information is accurate and according to specific working conditions requirements where the valve will be installed.

**For EU Directives and other Certificates, please see the document:
Directives & Certificates Compliance - Knife Gate Valves - IOM**

1. HANDLING

The valves are packed according to the appropriate transport standards. If you receive the packing damaged, please inform the transport company in writing and contact your ORBINOX representative.



When handling an ORBINOX valve please pay attention to the following points:

- DO NOT ATTACH LIFTING GEAR TO THE VALVE ACTUATORS OR GATE GUARDS. They are not designed to bear the weight, and could easily be damaged.
- DO NOT LIFT THE VALVE BY THE VALVE BORE.
This can cause damage to the seating surfaces and seals.
- Check that selected lifting gear is rated to carry the weight of the valve. The valve can be handled using eyebolts, soft straps or slings.

- **EYEBOLTS:** make sure the eyebolts have the same thread as the bolt holes and they are all well secured. Ideally when using lifting gear to move an ORBINOX valve, it should be supported by two or more eyebolts screwed into the tapped fixing holes in the valve body.
- **SOFT STRAPS:** with the valve in the closed position, the straps should be placed between the gland area and the bore such that the valve is balanced.

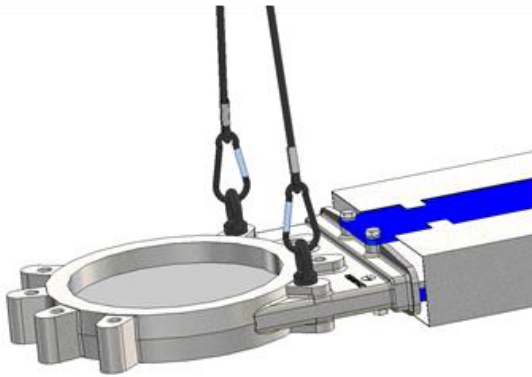

Fig. 1 Handling with eyebolts

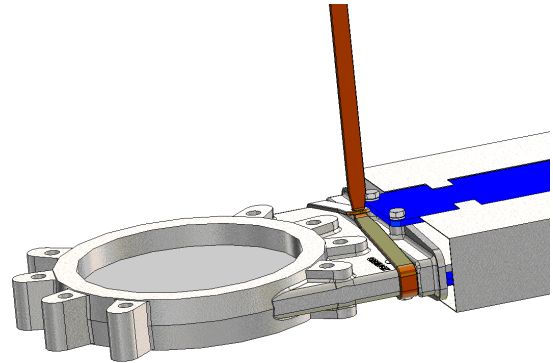
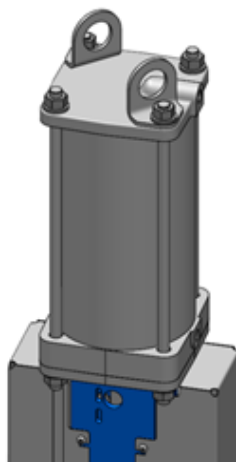

Fig. 2 Handling with soft straps

PNEUMATIC ACTUATED VALVES (Non-standard valves shall be checked case by case)

ORBINOX pneumatic valves (with Ø125 cylinder and above) are supplied with 2 lifting lugs for a safe handling of the valve for vertical movements



Handling WARNING:



Lifting lugs are not machined so they could have sharp corners; soft straps or slings are forbidden to be used with these lifting lugs

Below table shows the maximum weight of valve + pneumatic cylinder that 2 lifting lugs can hold depending on lifting chain angle (X):

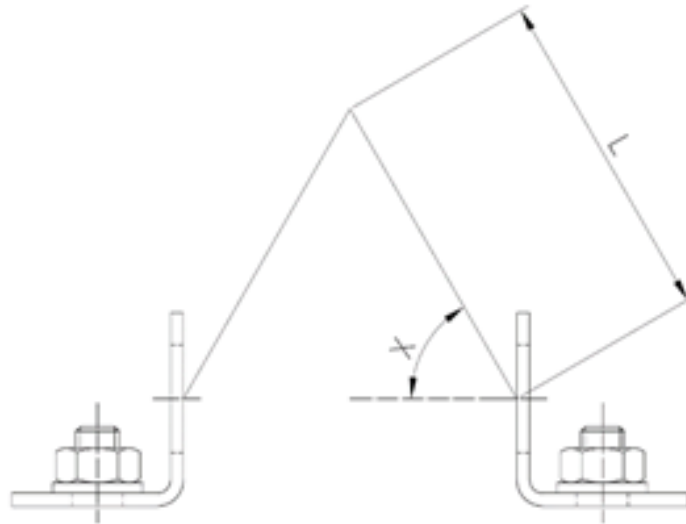

CYLINDER	With 2 lifting lugs: max. weight valve + cylinder (kg.)			
	L: minimum lifting chain length			
	X: 60°		X: 75°	
	Kg.	Lmin (mm)	Kg.	Lmin (mm)
125	170	130	310	220
160	270	170	500	280
200	390	220	710	380
250	740	300	1335	500
300	1140	360	2030	600
350	1615	440	2835	720
400	2105	500	3660	830

- For horizontal movement, the valve shall be lifted mainly from the body and the yoke. See above instructions for further instructions
- Cylinder's lifting lugs can only be used during horizontal movement of the valve to help balance the valve given the weight is hold at the body lifting point (center of gravity is approx. centered on the body)
- The valve can be lowered from vertical to horizontal position when it is hanging from the cylinder's lifting lugs

Below table shows approximate weight of standard EP pneumatic valves (kg):

DN (mm)	CYL.	Kg.
DN 50	CYL 100	10
DN 80		12
DN 100		15
DN 125	CYL 125	21
DN 150		27
DN 200	CYL 160	46
DN 250	CYL 200	70
DN 300		89
DN 350	CYL 250	135
DN 400		162
DN 450	CYL 300	212
DN 500		290
DN 600		375

2. INSTALLATION

**For EU Directives and other Certificates, please see the document:
Directives & Certificates Compliance - Knife Gate Valves - IOM**



In order to avoid personal injury or damage to property when handling and installing the valve, it is important to observe the following warnings:

- It is the User's responsibility to verify compatibility of valve parts materials with the internal fluid
- Qualified and trained personnel must carry out the handling and maintenance of the valve
- Use suitable Individual Protection Equipment (IPE) (gloves, safety footwear...)
- Disconnect all lines affecting the valve and put up a notice notifying that work is being carried out on the valve
- Isolate the valve completely from the process
- Release process pressure
- Drain the fluid from the valve

Before installation, inspect the valve body and components for any damage that may have occurred during shipping or storage. Make sure the internal cavities within the valve body are clean. Inspect the pipeline and mating flanges, making sure the pipe is free of foreign material and that the flanges are clean.

Special care should be taken to maintain the correct distance between the flanges and to ensure that they are parallel to the valve body. Incorrect alignment of the valve can cause deformations, which can lead to difficulties in operation.

The following table shows recommended torque values for the valve fixing bolts and the maximum depth (T) of blind tapped holes:

DN (inch/mm)	T (mm)	T (inch)	PN-10 (EN 1092-1)	CL150 (ASME B16.5/B16.47 Series A)	Torque (N.m)
2"/50	11	15/32"	M16	5/8" - 11 UNC	70 Nm
2,5"/65	11	15/32"	M16	5/8" - 11 UNC	70 Nm
3"/80	11	15/32"	M16	5/8" - 11 UNC	70 Nm
4"/100	9	11/32"	M16	5/8" - 11 UNC	70 Nm
5"/125	11	15/32"	M16	3/4" - 10 UNC	70 Nm
6"/150	13	3/8"	M20	3/4" - 10 UNC	140 Nm
8"/200	12	15/32"	M20	3/4" - 10 UNC	140 Nm
10"/250	12	15/32"	M20	7/8" - 9 UNC	140 Nm
12"/300	12	15/32"	M20	7/8" - 9 UNC	140 Nm
14"/350	15	19/32"	M20	1" - 8 UNC	140 Nm
16"/400	15	19/32"	M24	1" - 8 UNC	235 Nm
18"/450	15	19/32"	M24	1 1/8" - 7 UNC	235 Nm
20"/500	22	7/8"	M24	1 1/8" - 7 UNC	235 Nm
24"/600	22	7/8"	M27	1 1/4" - 7 UNC	350 Nm

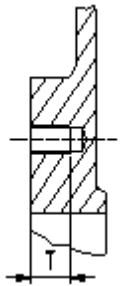

Select the recommended torque based on bolt size for other flange drilling patterns.
Make sure that cross-pattern tightening sequence is always followed.

The valve can be mounted in any position with regard to the pipe. However, it is advisable to place it vertically in horizontal pipeline (A) if the installation allows it. (Please consult the technical department at ORBINOX).

With larger diameters (> 300 mm), heavy actuators (pneumatic, electric, etc.), or with the valve installed horizontally (B) or at an angle (C) on a horizontal pipeline, the installation will require the construction of suitable supports. (See the following diagram and consult the technical department at ORBINOX).

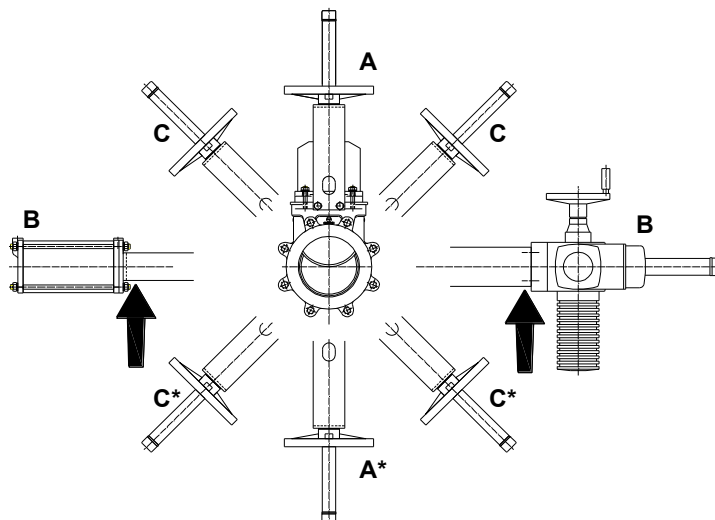

* For these positions please consult ORBINOX

The installation of suitable supports is advised when significant vibrations coming from the piping are present.

In vertical pipelines, the construction of suitable supports is always required (for further information please consult the technical department at ORBINOX).

Once the valve is installed, test that the flanges have been fastened correctly and that all electrical and/or pneumatic connections have been properly made.

First, operate the valve with no flow in the pipeline. Then test operation and valve seal with flow. It should be noted that the packing material might settle in shipping/storage, which can cause minor leakage. This can be solved by tightening the gland follower (5) during installation. The nuts shall be tightened gradually and crosswise until the leakage stops (see the next figure). Check that there is no metal contact between the glandfollower (5) and the gate (2).

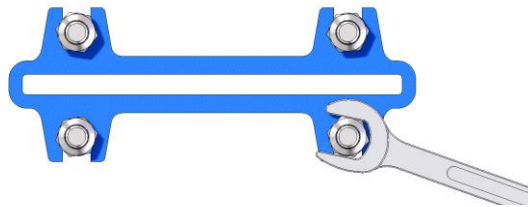

If the glandfollower nuts are overtorqued, the force needed to operate the valve will increase, the valve function will be affected and the box packing lifetime will be shortened.

The table below shows the recommended maximum torques for the glandfollower nuts. Overtorque might result in body and/or packing gland breakage.

DN	Torque (N.m)
50 - 200	15
250 - 300	25
350 - 600	30

Once performance has been tested, the valve can be put into operation.

Approximate weight of the handwheel-operated valve (rising stem):

DN (mm) : kg			
DN 50: 7kg	DN 125: 15 kg	DN 300: 58 kg	DN 500: 192 kg
DN 65: 8 kg	DN 150: 18 kg	DN 350: 96 kg	DN 600: 245 kg
DN 80: 9 kg	DN 200: 30 kg	DN 400: 124 kg	
DN 100: 11kg	DN 250: 44 kg	DN 450: 168 kg	

3. ACTUATORS

**For EU Directives and other Certificates, please see the document:
Directives & Certificates Compliance - Knife Gate Valves - IOM**

3.1. HANDWHEEL

Turn the hand wheel (9) anticlockwise to open the valve. Turn the hand wheel clockwise to close the valve.

3.2. LEVER

To operate the valve with this device, first loosen the locking clamp located on the top of the yoke (8). Then either open or close the valve by moving the lever in the desired direction. Finally, fix the position of the lever with the locking clamp.

3.3. PNEUMATIC

Valves are usually supplied with a double acting pneumatic actuator although, upon request, we can supply single-acting actuators. In either case the feed pressure can vary between 3,5 and 10 bar. However, the size of the actuator for each valve has been designed for a feed pressure of 6 bar.

It is essential for a good maintenance of the cylinder that air should be well dried, filtered and lubricated. Air quality shall fulfil the following requirements:

- ISO 8573-1 Grade 5:4:3 for regular process (ON / OFF services).
- ISO 8573-1 Grade 5:3:3 for regular process at low temperature (-20 °C).
- ISO 8573-1 Grade 3:4:3 for cylinders with positioners.
- ISO 8573-1 Grade 3:3:3 for cylinders with positioners at low temperature (-20 °C)

It is recommended to actuate the cylinder 3-4 times before the start up, once it is installed in the pipeline.

3.4. ELECTRIC ACTUATOR

Depending on the type or make of the electric actuator, specific instructions (i.e. a manufacturer's manual) will be supplied.

4. MAINTENANCE

**For EU Directives and other Certificates, please see the document:
Directives & Certificates Compliance - Knife Gate Valves - IOM**

The valve must not undergo any modifications without a previous agreement with ORBINOX. ORBINOX shall not be liable for any damages that may arise due to the use of non original parts or components



To avoid personal injury or damage to property from the release of process fluid:

- Those in charge of handling and maintenance of the valve must be qualified and trained in valve operations.
- Use appropriate personal protection equipment (gloves, safety shoes, etc).
- Shut off all operating lines to the valve and place a warning sign.
- Isolate the valve completely from the process.
- Release process pressure.
- Drain the process fluid from the valve.

The only maintenance required is to change the gland packing (4).

The life of these elements will depend on the working conditions of the valve such as: pressure, temperature, abrasion, chemical action, number of operations, etc.

4.1. Replacement of the gland packing (4):

1. Depressurise the circuit and place the valve in close position.
2. Remove the gate guards (for automatically actuated valves only).
3. Release the spindle or stem (6) from the gate (2). (Photo 1)
4. Loosen the screws of the yoke (8) and remove it (without losing the actuator).
- 5 Loosen the nuts of the gland follower (5) and remove it. (Photo 2)
6. Remove the old packing rings (4) and clean the stuffing box.
7. Insert the new packing rings (4), making sure that the ring joints alternate (the first on one side of the gate, the next on the other and so on). (Photo 3)
8. Once the necessary packing rings (4) have been inserted, proceed with a steady initial tightening of the gland follower (5).(Photo 2)



Photo 1



Photo 2



Photo 3

9. Place the yoke (8) (with the actuator) and screw it.
10. Fix the stem (6) to the gate (2). (Photo 1)
11. Remount the gate guards.
12. Carry out some operations with a loaded circuit and then re-tighten the gland follower (5) to prevent leakage.

4.2. Lubrication:

Lubricate the stem every 30 days with a calcium-based grease with the following characteristics: highly water resistant, low ash content, and excellent adherence

5. STORAGE

- For long storage periods keep the valves indoors in a safe and dry place and protect it from any impact and or vibrations
- Storing temperatures: -10°C to +40°C
- Valves must be stored in either full open or full closed position
- For any component installed in the valves, electric motors, solenoid valves, etc, please refer to their own instructions manuals

6. ENVIRONMENTAL CONSIDERATIONS

- The packaging is made from environmentally friendly materials. Dispose of the packaging through the available recycling channels
- The valve is designed and manufactured with materials that can be recycled by specialised recycling firms. Once the life of the product is expired, you have to consider a proper disposal of the product in order to prevent any negative impact on the environment and allows for the recycling of valuable commodities
- Please follow the local environmental rules in your country for proper disposal

7. PARTS LIST & DRAWINGS

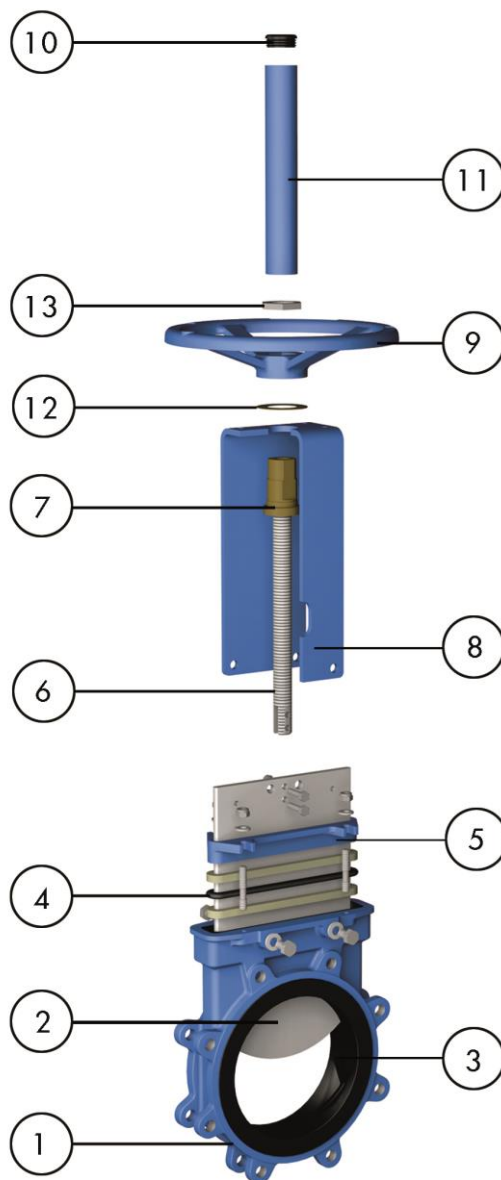

1. BODY	8. YOKE
2. GATE	9. HANDWHEEL
3. SEAT	10. CAP
4. PACKING	11. STEM PROTECTOR
5. GLAND FOLLOWER	12. FRICTION WASHER
6. STEM	13. NUT
7. STEM NUT	